

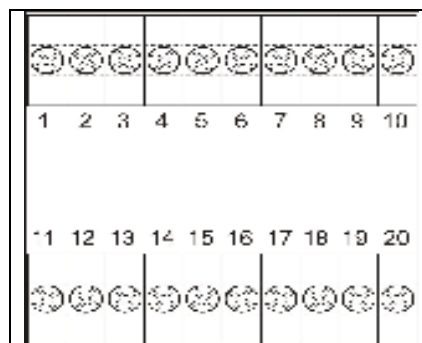

**OPERATING INSTRUCTIONS**  
**Product : Universal Temperature Controller**  
**Model : : EX9-Ua**

OPI No.: OPI/113  
PAGE : 01 of 03  
DATE : 30/01/2009

### Front panel layout:

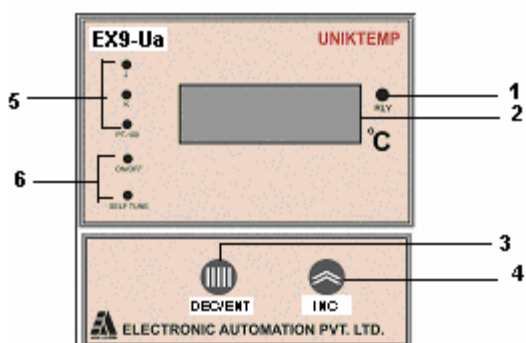

### Front Panel Details

1. **RELAY LED:** Indicates the relay status when the relay changeover takes place.
2. Display SET & PROCESS temperature
3. **SELECT:** Programming Switch
4. **ADVANCE:** Programming Switch
5. **SENSOR LED:** Indicates sensor selected
6. **FUNCTION LED:** Indicates function selected

### Terminal Details

- 1 Thermocouple +ve / RTD1
- 2 Thermocouple -ve / RTD2
- 3 RTD3 / Short 2,3 for 2 wire RTD
- 5 & 6 Short for program enable
- 11,12,13 NO , C , NC
- 19, 20 Source

### FUNCTION:

Uniktemp series Model EX9-Ua (96 x 96) series is a universal temperature controller with universal voltage input on same terminals, selectable sensor input with On/Off or self-tune function. On power application the display shows ambient temperature and depending on the function and set value, the unit controls the temperature.

### On/Off function:

In this mode, the controller switches off the load only when the process temperature equals or exceeds the set temperature. The load switches ON again after hysteresis.

### Self-tune function:

In self-tune function, relay will be ON continuously till process temperature reaches 50% of the set value, after reaching 50% relay on -off action starts. This On/Off cycle depends upon rate of change of temperature of heating system. Once process value reaches the set value, controller will automatically adjust the relay On & Off cycles, such that the set temperature is maintained.

### Universal Input voltage:

Uniktemp series operates with input voltage from 85V AC/DC to 270V AC/DC (Y-version) and provides wide operating voltage range.

Sensor open/Sensor reverse: It is indicated by 'SF' on display and relay is Off.

Universal Input: Uniktemp series accepts the universal input as per the table

Type of sensor	Temperature Range in deg C	Resolution	ON-OFF	Self Tuned
J type (Fe/K)	0 to 600	1	√	√
K type (Cr/Al)	0 to 1200	1	√	√
RTD (PT-100)	0 to 300(self-tune)	1	-	√
RTD (PT-100)	-100 to+300(On-Off)	1	√	-

#### SENSOR AND TERMINAL CONNECTIONS:

- 1) Short rear terminal 5 & 6 to enable programming.
- 2) Connect the sensor to the terminals as per the terminal details.
- 3) Connect the source voltage 85 to 270 VAC/DC to the terminals 1 & 2 and display shows ambient temperature.

#### SELECTION OF SENSOR AND FUNCTION:

- 1) Press the "DEC/ENT" button on front panel, the display shows "PRS" to program the type of sensor.
- 2) Press "INC" button on front panel to select the J,K or RTD sensors which is indicated by front panel LEDs.
- 3) Again press "DEC/ENT" button, display shows "PRF" to select the required On-Off or Self-tune function.
- 4) Press "INC" to select On/Off or self-tune functions.

#### PROGRAMING / SETTING OF DESIRED TEMPERAURE:

- 1) Press "DEC/ENT" button. The display shows C NN. Previously set ambient Offset.
- 2) Press "INC" to set Ambient offset from -20 to +20.
- 3) Press "DEC/ENT" button. The display shows H NN. Previously set hysteresis value.
- 4) Press "INC" Key set Hysteresis between 2 - 20.
- 5) Switch off the Power
- 6) Remove 5&6 line to lock programming configuration settings
- 7) Display shows process temperature.
- 8) DEC/ENT or INC key press for less than 3seconds, display shows set temperature.
- 9) DEC/ENT or INC key press for more than 3seconds, set value starts decrementing or incrementing by 1 respectively.
- 10) DEC/ENT or INC key press for more than 10seconds, set value starts decrementing or incrementing by 10 respectively.
- 11) After setting required set value, after 2 seconds unit enters into run mode.

### TYPICAL LOAD CONNECTION:

- 1) For heating application - Connect "NO" terminals (11) to the load, the other side of load to neutral and "C" terminal (12) to phase.
- 2) For cooling application (set value below ambient temperature) - Connect "NC" terminal (13) to load and other side of load to neutral, "C" terminal (12) to phase.

### PRECAUTION DURING USE:

- a) Connect RC filter provided with the controller, as shown in the diagram to avoid electrical noise interference, generated by switching OFF inductive loads.
- b) Use separate shielded wire for sensor input.

**Note:** In case of cooling system, set temperature at cooling system has to be switched ON and hysteresis to switch OFF the system.

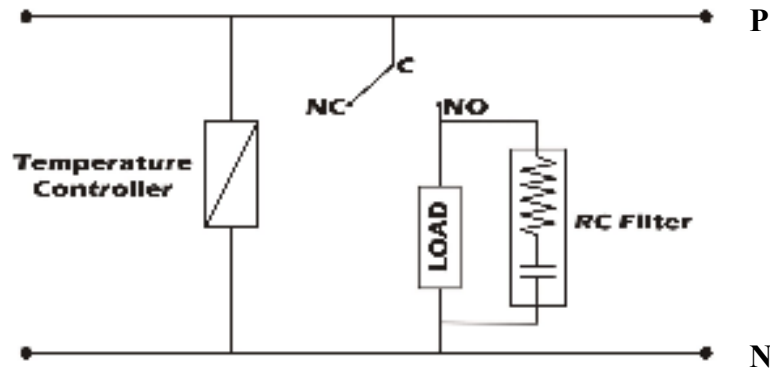

### **NOTE:**

- Usually the output is relay, SSR, 4-20mA or 0-10V DC.
- In unlikely event, these outputs can malfunction irrespective of which make of controller is used and hence our controller is not exception.
- Therefore customer should take care by using secondary protection like blind On/Off controller or thermal cut off protection to avoid any damage to the system.
- The end user is requested to study and decide the product to suit its application and environment. The company does not accept any consequential liabilities arising out of use of this product.