

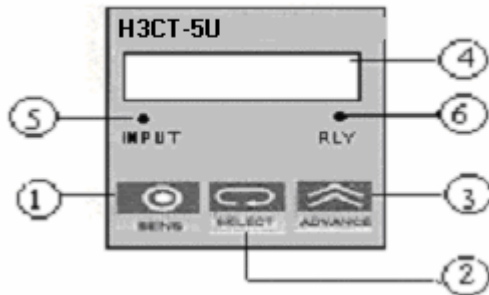

Front panel layout:



1. RESET : For resetting the counter
2. SELECT :
3. ADVANCE } : Used for programming
4. PROCESS : Displays Process/Set value.
5. INPUT : Indicates the input sensing.
6. RELAY LED : Indicates the relay status when the relay changeover takes place.

Terminal Details:

- 1,2 SOURCE
- 7,8 RESET
- 8,9 Short - Hold
Open - Restart
- 10,11,12 NC, C, NO

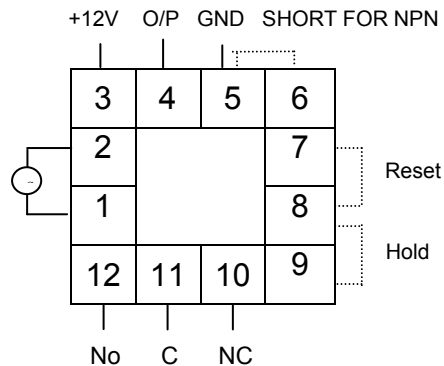

Sensor Input (NPN/PNP)

- 3 +12V DC
- 4 OUTPUT
- 5 GROUND
- For NPN or Pot.free signal Short terminals 5, 6 . For PNP terminals 5, 6 open
- For limit switch & potential free signals, use only terminals 4 & 5

H3CT-5U is a UP counting Preset Production Counter with RESTART/HOLD facility during power failure and accepts inputs from Proximity sensor or limit switch.

Function:

- Connect the sensor input terminals and apply rated voltage to the source terminals, the unit resumes its previous reading (Hold condition) or displays set value (Restart condition).
- To start counting from beginning, apply reset signal or press reset button, else counter will continue counting from the previous value.
- Set required count and sensitivity using "SELECT" & "ADVANCE" buttons.
- As the input signal is received through the sensor the unit starts counting up when process count reaches the set value, the output relay changes over and remains in this state till the Reset signal is applied.



















Special Instruction:

- To reset the counter short 7 and 8 for at least 250ms and release or else press reset button on front panel.
- During re-programming the counter resets and starts to count freshly upwards from 0 to set value (new value).

- Once Process Value reaches the set value relay comes ON and further counting in display stops even though sensor provides the counting signal.

How to program:

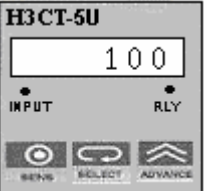
Example with Counts = 99999
SENSITIVITY =100

<p>Step 1</p> <ul style="list-style-type: none"> • Press SELECT  once • Display shows 'Set' for few seconds and then shows previous set value with flashing most significant digit. • Press ADVANCE  till display shows 9. 	<p>Step 2</p> <ul style="list-style-type: none"> • Press SELECT  again, 2nd digit starts Flashing. 
<p>Step 3</p> <ul style="list-style-type: none"> • Press ADVANCE  till display shows 9 	<p>Step 4</p> <ul style="list-style-type: none"> • Press SELECT  again, 3rd digit starts flashing • Press ADVANCE  till display shows 9. • Press SELECT  again, 4th digit starts flashing. • Press ADVANCE  till display shows 9. • Press SELECT  again, 5th digit starts flashing. • Press ADVANCE  till display shows 9.
<p>Step 5</p> <ul style="list-style-type: none"> • Press SELECT  again, the display shows sens and set value is saved in memory and the display shows previous sensitivity value  	<p>Step 6</p> <ul style="list-style-type: none"> • Press ADVANCE  till the display shows 100 
<p>Step 7</p> <p>Press SELECT  again, the counter transfers itself to run mode and the display shows the set value</p>	<ul style="list-style-type: none"> • Same procedure shall be followed for different counts and sensitivity values.