

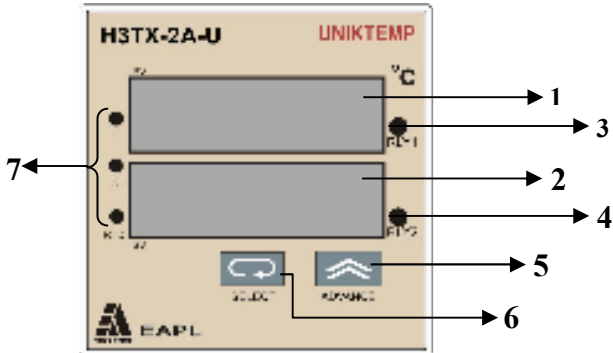

**OPERATING INSTRUCTIONS**  
**Product : Universal Temperature Controller**  
**Model : : H3TX-2H-U / H3TX-2A-U**

OPI No.:	OPI/075
PAGE	: 01 of 03
DATE	: 22/11/2007

**Front panel layout:**



**Front Panel Details:**

1. **Display:** PROCESS temperature.
2. **Display:** SET temperature.
3. **RELAY 1 LED:** Indicates the relay status when the relay changeover takes place for first set temp.
4. **RELAY 2 LED:** Indicates the relay status when the relay changeover takes place for second set temp.
5. **ADVANCE:** Programming Switch
6. **SELECT:** Programming Switch
7. **SENSOR LED:** Indicates Sensor selected

**Terminal Details**

- 1&2 : Source voltage (85 to 270V AC/DC)
- 3 : +ve / RTD 1
- 4 : -ve / RTD 2
- 5 : RTD 3
- 7, 8 , 9 : NC2 , C2 , NO2
- 10, 11,12 : NC1 , C1 , NO1

**Note:**

For 2 wire RTD probe (Short 4&5)  
Short terminal 5&6 for Program enable

**FUNCTION:**

Uniktemp series model H3TX-2H-U(Heater type) / H3TX-2A-U(Alarm type) ( 48 x 48 ) is a universal temperature controller with universal voltage input on same terminals, selectable sensor input with On/Off function. Controls maximum two level of temperature.

**Heater Type (H3TX-2H-U):** On power application the PV(Process Value) display shows ambient temperature and if PV < SV1 (Set Value 1) & SV2 (Set Value 2) both the relays will be ON. RLY1 (Relay 1) will be OFF when PV  $\geq$  SV1. RLY2 (Relay 2) will be OFF when PV  $\geq$  SV2. Again RLY1 will come ON when PV = SV1-Hyst1(Hysterisis1) and RLY2 will come ON when PV = SV2 - Hyst2(Hysterisis2).

**Alarm Type (H3TX-2A-U):** On power application the PV(Process Value) display shows ambient temperature. Initially when PV < SV1 (Set Value 1) RLY1 will be ON and RLY2 will be OFF. RLY1 will be OFF when PV  $\geq$  SV1. RLY2 will be ON when PV  $\geq$  SV2. Again RLY1 will come ON when PV = SV1-Hyst1(Hysterisis1) and RLY2 will come OFF when PV = SV2 - Hyst2(Hysterisis2).

**Universal Input voltage:**

Uniktemp series operates with input voltage from 85V AC/DC to 270V AC/DC (Y-version) and provides wide operating voltage range.

Sensor open/Sensor reverse: It is indicated by 'SF' on display and relay is Off.

Universal Input: Uniktemp series accepts the universal input as per the table

Type of sensor	Temperature Range in deg C	Resolution
J type (Fe/K)	0 to 600	1
K type (Cr/Al)	0 to 1200	1
RTD (PT-100)	0 to 300	1

#### SENSOR AND TERMINAL CONNECTIONS:

- 1) Short the Program Enable terminals (5 & 6).
- 2) Connect the sensor to the terminals as per the terminal details.
- 3) Connect the source voltage 85 to 270V AC/DC to the terminals 1 & 2 and display shows ambient temperature.

#### SELECTION OF SENSOR AND FUNCTION:

- 1) Press the "SELECT" button on front panel, the display shows "PRS" to program the type of sensor.
- 2) Press "ADVANCE" button on front panel to select the J,K or RTD sensors which is indicated by front panel LEDs.

#### PROGRAMING / SETTING OF DESIRED TEMPERATURE:

- 1) Press SELECT switch, PV display shows SET 1 and SV display shows previously programmed set value1 with most significant digit blinking
- 2) Use ADVANCE switch to increment the blinking digit.
- 3) To adjust the next digit, press SELECT switch and shift the blinking position.
- 4) After the 4 digit are set, Press SELECT switch , the bottom display shows the earlier setting viz. 'H02' with '0' blinking the desired hysteresis value can be selected by pressing advance button between 2 to 20 degree.
- 5) Press SELECT switch PV display shows SET2 & SV display shows previously programmed set value 2 with most significant digit blinking.
- 6) Use ADVANCE switch to increment the blinking digit.
- 7) To adjust the next digit, press SELECT switch and shift the blinking position. After the 4 digit are set, press SELECT and set the hysteresis value for the set point 2. Once both set point are programmed, press SELECT switch, the front panel display shows process value and set value (Set value 1 will be displayed as long as Process Value < Set Value 1 & then set value 2 will be displayed as long as Process Value < Set Value 2.

- 8) Set value cannot be programmed beyond 1200 for K / 600 for J / 300 for RTD.

### TYPICAL LOAD CONNECTION:

1) For heater type

- Connect "NO2" terminal (9) to the load, the other side of load to neutral and "C2" terminal (8) to phase.
- Connect "NO1" terminal (12) to the load, the other side of load to neutral and "C1" terminal (11) to phase.

2) For Alarm type (for heating & cooling application)

- Connect "NO1" terminal (12) to the load, the other side of load to neutral and "C1" terminal (11) to phase for heating system.
- Connect "NO2" terminal (9) to the load, the other side of load to neutral and "C2" terminal (8) to phase for cooling system..

### PRECAUTION DURING USE:

a) Connect RC filter provided with the controller, as shown in the diagram to avoid electrical noise interference, generated by switching Off inductive loads.

b) Use separate shielded wire for sensor input.

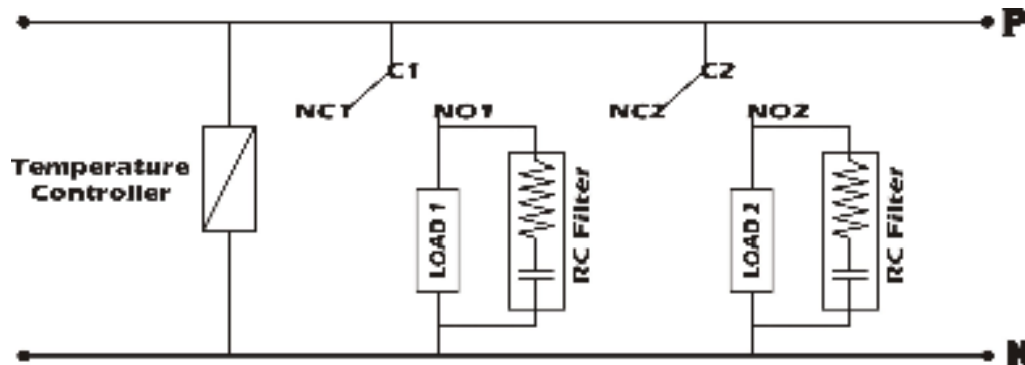

### NOTE:

- Usually the output is relay, SSR, 4-20mA or 0-10V DC.
- In unlikely event, these outputs can malfunction irrespective of which make of controller is used and hence our controller is not exception.
- Therefore customer should take care by using secondary protection like blind On/Off controller or thermal cut off protection to avoid any damage to the system.
- The end-user is requested to study and decide the product to suit its application and environment. The company does not accept any consequential liabilities arising out of use of this product.