



**OPERATING INSTRUCTIONS**  
**Product : Temperature Controller**  
**Model : : H3TX-2U**

OPI No.: OPI/088

PAGE : 01 of 04

DATE : 10/03/2008

Front panel layout:

Front Panel Details:

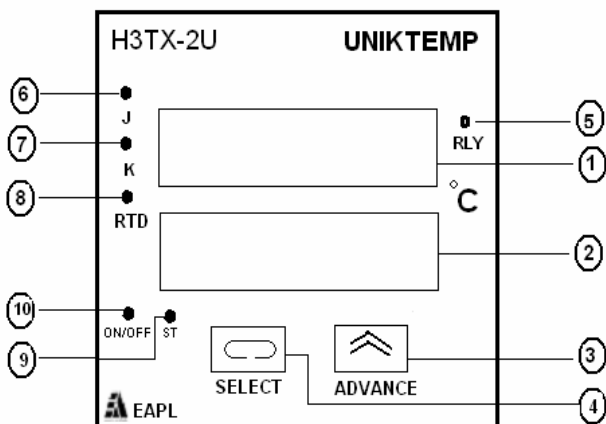

1. **PROCESS**: Displays the process value.
2. **SET**: Displays the set value.
3. **ADVANCE**: Change configuration setting and increment set values
4. **SELECT**: Programming Switch
5. **RELAY LED**: Indicates the relay status when the relay changeover takes place.
6. **J Type Sensor**: LED Glows when sensor J type is selected
7. **K Type Sensor**: LED Glows when sensor K type is selected
8. **PT 100**: LED Glows when sensor PT100 is selected
9. **ON/OFF**: LED Glows when function On-Off selected
10. **Self Tune**: LED Glows when function self tune selected

Terminal Details

3	4	5	6
2			7
1			8
12	11	10	9

- 1, 2 : Source
- 3 : TC +/RTD1
- 4 : TC -/RTD2
- 5 : RTD3/ Short 4,5 for 2 wire RTD
- 10,11,12 : NC, C, NO
- 5 & 6 : Short for Program Enable

FUNCTION:

Uniktemp series is a universal temperature controller with universal sensor input on same terminals, selectable sensor input on same terminals with On/Off or self-tune function. On power application the display shows ambient temperature and depending on the function and set value, the unit controls the temperature.

On/Off function:

In this mode, the controller switches off the load only when the process temperature equals or exceeds the set temperature. The load switches ON again after hysteresis.

Self-tune function:

In self-tune function, relay will be ON continuously till process temperature reaches 50% of the set value, after reaching 50% relay on -off action starts. This On/Off cycle depends upon rate of change of temperature of heating system. Once process value reaches the set value, controller will automatically adjust the relay On & Off cycles, such that the set temperature is maintained.

### Universal Input voltage:

Uniktemp series operates with input voltage from 85 V AC/DC to 270 VAC/DC (Y-version) and provides wide operating voltage range.

Sensor open: It is indicated by 'SF' on display and relay is Off.

Sensor reverse: The temperature decreases and shows SF when display is below 0 degree.

Universal Input: Uniktemp series accepts the universal input as per the table

Type of sensor	Temperature Range in deg C	Resolution	ON-OFF	Self Tuned
J type (Fe/K)	0 to 600	1	√	√
K type (Cr/Al)	0 to 1200	1	√	√
RTD (PT-100)	0 to 300 (self-tune)	1	-	√
RTD (PT-100)	-100 to+300 (On-Off)	1	√	-

### SENSOR AND TERMINAL CONNECTIONS:

- 1) Short rear terminal 5 & 6 to enable programming.
- 2) Connect the sensor to the terminals as per the terminal details.
- 3) Connect the source voltage 85 to 270 VAC/DC to the terminals 1 & 2 and display shows ambient temperature.

### SELECTION OF SENSOR AND FUNCTION:

- 1) Press the "SELECT" button on front panel, the process display shows "PRS" to program the type of sensor and set display shows earlier set value.
- 2) Press "ADVANCE" button on front panel to select the J,K or RTD sensors which is indicated by front panel LEDs.
- 3) Again press "SELECT" button, process display shows "PRF" to select the required On-Off or Self-tune function and set display still shows earlier set value.
- 4) Press "ADVANCE" to select On/Off or self-tune functions.

### PROGRAMING / SETTING OF DESIRED TEMPERAURE:

- 1) Press "SELECT" button. The process display shows "Prog" and in the set display, the first Most Significant Digit will be seen blinking.
  - a) If RTD sensor is being used, then you can select whether temperature to be set is -ve or +ve by using ADVANCE button (If +ve is selected, then display screen will show zero, else -ve sign will be displayed).
  - b) If "K" thermocouple is being used, you can toggle between 0 & 1 by pressing ADVANCE button.
  - c) If "J" thermocouple is being used, you can skip this step.

- 2) Repeat the Step 2 for setting the second Most Significant Digit, the third Most Significant Digit and Least Significant Digit for setting the required set value.
- 3) Once the required temperature has been set, press the SELECT button for setting hysteresis in case of On/Off function.
  - d) In case function On/Off have been selected, set display shows the earlier setting viz. "H03" with "0" blinking. The desired hysteresis can be selected by pressing the ADVANCE button which rolls between 0, 1 & 2. Press select button and Least Significant Digit blinks, select required digit by using Advance button.
  - e) In case function self tune has been selected, this step gets bypassed.
- 4) Press SELECT button. The ambient/actual temperature is displayed on the screen and then switch Off the power.
- 5) Take out the link from the terminals 5 & 6 to avoid any unauthorized tampering (only PRS & PRF gets locked and operator can still change set values).
- 6) Switch On the power and the unit is ready for process.

#### TYPICAL LOAD CONNECTION:

- 1) For heating application - Connect "NO" terminals (12) to the load, the other side of load to neutral and "C" terminal (11) to phase.
- 2) For cooling application (set value below ambient temperature) - Connect "NC" terminal (10) to load and other side of load to neutral, "C" terminal (11) to phase.

#### PRECAUTION DURING USE:

- a) Connect RC filter provided with the controller, as shown in the diagram to avoid electrical noise interference, generated by switching Off inductive loads.
- b) Use separate shielded wire for input.

**Note:** In case of cooling system, set temperature at cooling system has to be switched On and hysteresis to switch Off the system.

E.g: Set temperature is 18°C & hysteresis is 2° will switch on cooling at 18°C & switch off at 16°. (i.e, maintains temperature between 16 & 18 degrees)

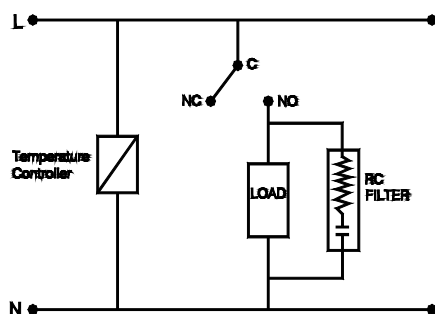

NOTE :

- Usually the output is relay, SSR, 4-20mA or 0-10V.
- In unlikely event, these outputs can malfunction irrespective of which make of controller is used and hence our controller is not exception.
- Therefore customer should take care by using secondary protection like blind On/Off controller or thermal cut off protection to avoid any damage to the system.
- The end user is requested to study and decide the product to suit its application and environment. The company does not accept any consequential liabilities arising out of use of this product.