

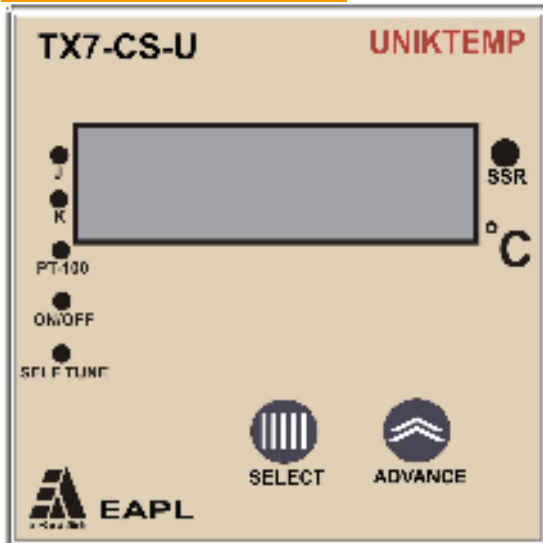

OPERATING INSTRUCTIONS
Product : Temperature Controller
Model : : TX7-CS-U

OPI No.:	OPI/080
PAGE	: 01 of 04
DATE	: 12/01/2008

Front panel layout:



Front Panel Details

1. **Display** SET / PROCESS temperature.
2. **RELAY LED**: Indicates the relay status when the relay changeover takes place.
3. **SELECT**: Programming Switch
4. **ADVANCE**: Programming Switch
5. **J/K/PT100** : Sensors selected
6. **ON/OFF/SELF TUNED LED**: Function selected

Terminal Details

- 1 - TC Positive/ RTD1
- 2 } - TC Negative/RTD2 } short for
- 3 } - 3w RTD } 2w RTD
- 4 Program enable
- 9 - Positive SSR Drive
- 10 - Negative output
- 11 } Universal Input
- 12 } Voltage
- D Type Connector - For RS232 communication

FUNCTION:

Uniktemp series is a universal temperature controller with universal voltage input on same terminals, selectable sensor input with On/Off and in tune with self-tune function. On power application the display shows ambient temperature and depending on the function and set value, the unit controls the temperature.

On/Off function:

In this mode, the SSR drive is on till the process value reaches set value. Above the set value the SSR drive will be Off condition. SSR drive is ON again when process value = set value - hysteresis.

Self-tune function:

In self-tune function, SSR drive will be ON continuously till process temperature reaches 50% of the set value, after reaching 50% SSR drive on - off action starts and reaches the set temperature. By this relay on-off action temperature settles very close to the set value.

Universal Input voltage:

Uniktemp series operates with input voltage from 85 VAC/DC to 270 VAC/DC (Y-version) and provides wide operating voltage range.

Sensor open/Sensor reverse: It is indicated by 'SF' on display and relay is Off in this condition.

Universal Input: Uniktemp series accepts the universal input as per the table

Type of sensor	Temperature Range in deg C	Resolution	ON-OFF	Self Tuned
J type (Fe/K)	0 to 600	1	√	√
K type (Cr/Al)	0 to 1200	1	√	√
RTD (PT-100)	0 to 300	1	-	√
RTD (PT-100)	-100 to+300	1	√	-

SENSOR AND TERMINAL CONNECTIONS:

- 1) Short rear terminal 3&4 to enable programming.
- 2) Connect the sensor to the terminals as per the terminal details.
- 3) Connect the source voltage 85 V AC/DC to 270 VAC/DC to the terminals 11 & 12 and display shows ambient temperature.

SELECTION OF SENSOR AND FUNCTION:

- 1) Press the "SELECT" button on front panel, the display shows "PRS" to program the type of sensor.
- 2) Press "ADVANCE" button on front panel to select the J,K or RTD sensors which is indicated by front panel LEDs.
- 3) Again press "SELECT" button, display shows "PRF" to select the required On-Off or Self-tune function.
- 4) Press "ADVANCE" to select On/Off or self-tune functions.

Note: After programming the sensor selection or function selection, turn OFF the power.

PROGRAMING / SETTING OF DESIRED TEMPERAURE:

- 1) Press "SELECT" button. The first Most Significant Digit will be seen blinking.
 - a) If RTD sensor is being used, then you can select whether temperature to be set is -ve or +ve by using ADVANCE button (If +ve is selected, then display screen will show zero, else -ve sign will be displayed).

- b) If "K" thermocouple is being used, you can toggle between 0 & 1 by pressing ADVANCE button.
- c) If "J" thermocouple is being used, you can skip this step.
- 2) Press SELECT button. The second Most Significant Digit will be seen blinking. By pressing ADVANCE button select the desired digit.
- 3) Repeat the Step 2 for setting the third Most Significant Digit and Least Significant Digit.
- 4) Once the required temperature has been set, press the SELECT button for setting hysteresis in case of On/Off function.
 - d) In case function On/Off has been selected, screen will display the earlier setting viz. "H03" with "0" blinking. The desired hysteresis can be selected by pressing the ADVANCE button between 2 to 20 degrees centigrade.
 - e) In case function self tune has been selected, this step gets bypassed.
- 5) Press SELECT button. The ambient/actual temperature is displayed on the screen and then switch Off the power.
- 6) Take out the link from the terminals 3 & 4 to avoid any unauthorized tampering.
- 7) Switch ON the power and the unit is ready for process.

Communication: RS232 Type

Connect RS232 cable to the D-type connector of the TX7-CS-U unit. Switch 'ON' computer. Go to start - programs - Accessories - communications - Hyper Terminal.

Enter a name for new connection.

Select COM port depending on the port on PC.

Refer table for port setting.

Bits per second	9600
Data bits	8
Parity	None
Stop bits	1
Flow control	None

Switch 'ON' the controller.

In hyper terminal screen we can see the information in following format for every 5 second updation.

Display pattern : EAPL
UNIVERSAL TEMPERATURE CONTROLLER
Model no.: TX7-CS-U
Function : ;Type : ; SV : ; PV : ;

TYPICAL LOAD CONNECTION:

- 1) For heating application - Connect "NO" terminals (7) to the load, the other side of load to neutral and "C" terminal (8) to phase.
- 2) For cooling application (set value below ambient temperature) - Connect "NC" terminal (9) to load and other side of load to neutral, "C" terminal (8) to phase.

PRECAUTION DURING USE:

- a) Connect RC filter provided with the controller, as shown in the diagram to avoid electrical noise interference, generated by switching Off inductive loads.
- b) Use separate shielded wire for input.

Note: In case of cooling system, set temperature at cooling system has to be switched ON and hysteresis to switch Off the system.

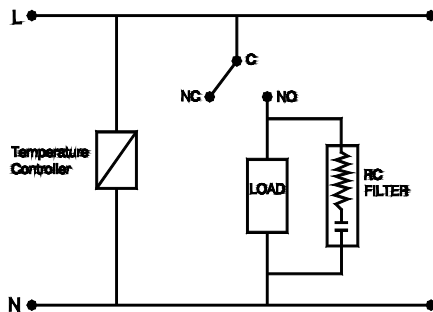

NOTE :

- Usually the output is relay, SSR, 4-20mA or 0-10V.
- In unlikely event, these outputs can malfunction irrespective of which make of controller is used and hence our controller is not exception.
- Therefore customer should take care by using secondary protection like blind On/Off controller or thermal cut off protection to avoid any damage to the system.
- The end user is requested to study and decide the product to suit its application and environment. The company does not accept any consequential liabilities arising out of use of this product.