

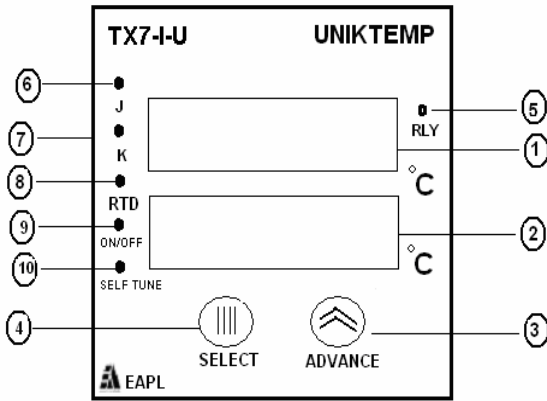

OPERATING INSTRUCTIONS
Product : Temperature Controller
Model : : TX7-I-U

OPI No.: OPI/091
 PAGE : 01 of 04
 DATE : 26/03/2008

Front panel layout:



Terminal Details:

1. **PROCESS:** Displays the process value.
2. **SET:** Displays the set value.
3. **ADVANCE :** Increases current selected parameter value
4. **SELECT:** Selects next parameter to be programmed
5. **RELAY LED:** Indicates the relay status
6. **J Type Sensor:** LED glows when J type sensor is selected
7. **K Type Sensor:** LED glows when K type sensor is selected
8. **PT 100 :** LED glows when PT100 sensor is selected
9. **ON/OFF:** LED glows when ON-OFF function is selected
10. **Self Tune:** LED glows when Self-tune function is selected

Terminal Details:

1	2	3	4	5	6
7	8	9	10	11	12

Terminal Details

- 11,12 : Universal Input Voltage
- 1 : TC +/RTD1
- 2 : TC -/RTD2
- 3 : RTD3/ Short 2,3 for 2 wire RTD
- 7,8,9 : NO, C, NC
- 3 & 4 : Short for Program Enable
- 5 : 4-20mA
- 6 : (Max. load 500Ω)

FUNCTION:

Uniktemp series is a universal temperature controller with universal sensor input on same terminals, selectable sensor input on same terminals with On/Off or self-tune function. On power application the display shows ambient temperature and depending on the function and set value, the unit controls the temperature.

On/Off function:

In this mode, the controller switches off the load only when the process temperature equals or exceeds the set temperature. The load switches ON again after hysteresis.

Self-tune function:

In self-tune function, relay will be ON continuously till process temperature reaches 50% of the set value, after reaching 50% relay on -off action starts. This On/Off cycle depends upon rate of change of temperature of heating system. Once process value reaches the set value, controller will automatically adjust the relay On & Off cycles, such that the set temperature is maintained.

Universal Input voltage:

Uniktemp series operates with input voltage from 85 VAC/DC to 270 VAC/DC (Y-version) and provides wide operating voltage range.

Sensor open: It is indicated by 'SF' on display and relay is Off.

Sensor reverse: The temperature decreases and shows SF when display is below 0 degree.

Universal Input: Uniktemp. series accepts the universal input as per the table

Type of sensor	Temperature Range in deg C	Resolution	ON-OFF	Self Tuned
J type (Fe/K)	0 to 600	1	√	√
K type (Cr/Al)	0 to 1200	1	√	√
RTD (PT-100)	0 to 300	1	√	√

Retransmission Output: Range 4-20mA. The output is scaled by use of analog and high scaling points. The analog output is proportional to process value. Analog low corresponds to 4mA. Analog high corresponds to 20mA.

SENSOR AND TERMINAL CONNECTIONS:

- 1) Short rear terminal 3 & 4 to enable programming.
- 2) Connect the sensor to the terminals as per the terminal details.
- 3) Connect the source voltage 85 to 270V AC/DC to the terminals 11 & 12 and display shows ambient temperature.

SELECTION OF SENSOR AND FUNCTION:

- 1) Press the "SELECT" button on front panel, the process display shows "PRS" to program the type of sensor and set display shows earlier set value.
- 2) Press "ADVANCE" button on front panel to select the J,K or RTD sensors which is indicated by front panel LEDs.
- 3) Again press "SELECT" button, process display shows "PRF" to select the required On-Off or Self-tune function and set display still shows earlier set value.
- 4) Press "ADVANCE" to select On/Off or self-tune functions.

SELECTION OF ANALOG HIGH SCALING VALUE & ANALOG LOW SCALING VALUE

1. Press SELECT button. The process window will show ANH and in the set window, First Most Significant Digit will blink.
2. By pressing ADVANCE button, set the required digit. Note this step can be skipped when J & PT100 sensors are used. For K type, it will toggle between 0 & 1.
3. Repeat step 1 & 2 and set values for the 2nd Most Significant Digit, Third Most Significant Digit and Least Significant Digit.
4. After setting ANH, press SELECT button once again. It will show ANL in process window and First Most Significant Digit and will blink in the set window.
5. Follow steps 1,2 & 3 to set ANL values.

PROGRAMMING / SETTING OF DESIRED TEMPERAURE:

- 1) Press "SELECT" button. The process display shows "Prog" and in the set display, the first Most Significant Digit will be seen blinking.
 - a) If "K" thermocouple is being used, you can toggle between 0 & 1 by pressing ADVANCE button.
 - b) If "J" thermocouple & RTD sensor is being used, you can skip this step.
- 2) Repeat the Step 2 for setting the second Most Significant Digit, the third Most Significant Digit and Least Significant Digit for setting the required set value.
- 3) Once the required temperature has been set, press the SELECT button for setting hysteresis in case of On/Off function.
 - c) In case function On/Off has been selected, set display shows the earlier setting viz. "H03" with "0" blinking. The desired hysteresis can be selected by pressing the ADVANCE button which rolls between 0,1 & 2. Press select button and Least Significant Digit blinks, select required digit by using Advance button.
 - d) In case function self tune has been selected, this step gets bypassed.
- 4) Press SELECT button. The ambient/actual temperature is displayed on the process display screen and set value on the set display screen. Switch Off the power.
- 5) Take out the link from the terminals 3 & 4 to avoid any unauthorized tampering (Only PRS, PRF, ANH & ANL gets locked and the operator can still change set values).
- 6) Switch ON the power and the unit is ready for process.

TYPICAL LOAD CONNECTION:

- 1) For heating application - Connect "NO" terminals (7) to the load, the other side of load to neutral and "C" terminal (8) to phase.
- 2) For cooling application (set value below ambient temperature) - Connect "NC" terminal (9) to load and other side of load to neutral, "C" terminal (8) to phase.

PRECAUTION DURING USE:

- a) Connect RC filter provided with the controller, as shown in the diagram to avoid electrical noise interference, generated by switching OFF inductive loads.
- b) Use separate shielded wire for input.

Note: In case of cooling system, set temperature at cooling system has to be switched ON and hysteresis to switch OFF the system.

E.g.: Set temperature is 18°C and hysteresis is 2° will switch ON and cooling at 18°C and switch Off at 16° (i.e, maintains temperature between 16 & 18 degrees).

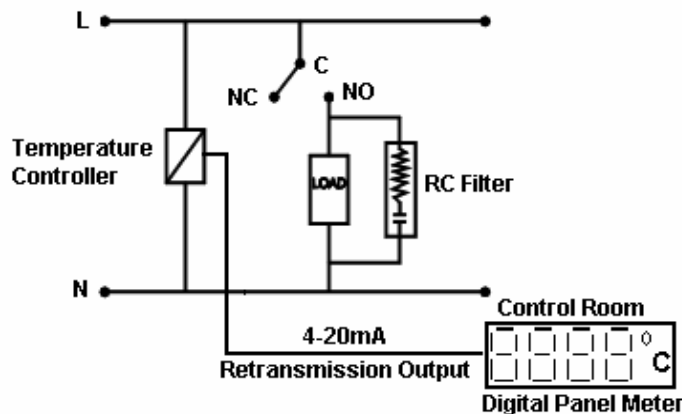

NOTE:

- Usually the output is relay, SSR, 4-20mA or 0-10V.
- In unlikely event, these outputs can malfunction irrespective of which make of controller is used and hence our controller is not exception.
- Therefore customer should take care by using secondary protection like blind On/Off controller or thermal cut off protection to avoid any damage to the system.
- The end user is requested to study and decide the product to suit its application and environment. The company does not accept any consequential liabilities arising out of use of this product.